



NSF-1...  
NSF-1K/40



NSF-3E...6E



NSF-2...PL



NSF

## LIQUID FLOW SWITCHES

### FUNCTION

Flow control of aggressive media, water and normal media (depending on model).

Alarm signal of flow shortage (safety switch).

Available in brass, suitable for normal media, and in stainless steel AISI316L, suitable for sea water and aggressive media.

### APPLICATIONS

Well-suited in pipes of general industrial plants:

- heating and air conditioning systems;
- refrigeration systems;
- sprinkler or anti-fire systems;
- heat pumps;
- devices for oil monitoring;
- lubrication circuits.

TYPE	PIPE Ø	MAX PRESSURE bar	NORMAL MEDIA (body in brass)	AGRESSIVE MEDIA (body in stainless steel AISI 316L)	BODY WITH PIPE FITTING "T"	PROTECTION	FLOW RATE
NSF-1K	1...8"	11	•			IP65	1
NSF-1K/40	1...8"	11	•			IP40	1
NSF-1K/NPT	1...8"	11	•				1
NSF-1KPL	1...8"	11	•				1
NSF-1E*	1...8"	11	•			IP65	1
NSF-1EPL*	1...8"	11	•				1
NSF-1RE	1...8"	11	•			IP65	2
NSF-2E**	1...8"	30		•		IP65	1
NSF-2EPL**	1...8"	30		•			1
NSF-2RE	1...8"	30		•		IP65	2
NSF-2REPL	1...8"	30		•			2
NSF-3E	1/2"	11	•		•	IP65	3
NSF-4E	3/4"	11	•		•	IP65	3
NSF-6E	1"	11	•		•	IP65	3
Accessories	DBZ-09 - Stainless steel Aisi 316L paddles for liquid flow switch						

**NPT** 1" NPT connector  
**PL** ABS cover, Byblend base (IP65)

\* models with TÜV approval S 09-025  
\*\* models with TÜV approval SW(SB) 07-026

### TECHNICAL FEATURES

**Contacts:** dust-tight microswitch with switching contacts (n.c./n.o.)  
**Switch capacity:** 15 (8) A, 24...250 Vac  
**Working:** -40...+85 °C  
10...90% r.h. (non condensing)

**Max liquid temperature:** -40...+120 °C  
**Max pressure:** 11 bar (NSF-2: 30 bar)  
**Fitting:** see flow rate schedule  
**Body:** see schedule above  
**Paddles:** stainless steel AISI 316L  
**Housing:** galvanized steel sheet plate, ABS cover  
version PL: Byblend base, ABS cover

**Protection:** IP65, class I  
**Size:** 113 x 70 x 65 mm  
version PL: 108 x 70 x 72 mm  
**Peso:** 950 g



①

**H<sub>2</sub>O FLOW RATE**  
NSF-1K / NSF-1E / NSF-2E

Pipe connector Ø	Qmax m <sup>3</sup> /h recommended	Min. adjustment m <sup>3</sup> /h cut-off (cut-in)	Max. adjustment m <sup>3</sup> /h cut-off (cut-in)
1"	3,6	0,6 (1,0)	2,0 (2,1)
1 1/4"	6,0	0,8 (1,3)	2,8 (3,0)
1 1/2"	9,0	1,1 (1,7)	3,7 (4,0)
2"	15,0	2,2 (3,1)	5,7 (6,1)
2 1/2"	24,0	2,7 (4,0)	6,5 (7,0)
3"	36,0	4,3 (6,2)	10,7 (11,4)
4"	60,0	11,4 (14,7)	27,7 (29,0)
4" Z	60,0	6,1 (8,0)	17,3 (18,4)
5"	94,0	22,9 (28,4)	53,3 (55,6)
5" Z	94,0	9,3 (12,9)	25,2 (26,8)
6"	120,0	35,9 (43,1)	81,7 (85,1)
6" Z	120,0	12,3 (16,8)	30,6 (32,7)
8"	240,0	72,6 (85,1)	165,7 (172,5)
8" Z	240,0	38,6 (46,5)	90,8 (94,2)

②

**H<sub>2</sub>O FLOW RATE**  
NSF-1RE / NSF-2RE

Pipe connector Ø	Min. adjustment m <sup>3</sup> /h cut-off (cut-in)	Max. adjustment m <sup>3</sup> /h cut-off (cut-in)
1"	0,2 (0,6)	1,0 (1,1)
1 1/4"	0,25 (0,9)	1,4 (1,6)
1 1/2"	0,5 (1,2)	1,6 (2,2)
2"	0,9 (2,3)	3,6 (4,1)
2 1/2"	1,2 (3,1)	4,9 (5,5)
3"	2,1 (4,9)	7,4 (8,2)
4"	4,9 (11,3)	17,1 (19,1)
4" Z	3,3 (7,7)	11,6 (13,0)
5"	9,7 (22,4)	34,0 (37,9)
5" Z	5,0 (11,5)	17,5 (19,6)
6"	13,6 (31,5)	47,6 (53,2)
6" Z	6,1 (14,1)	21,4 (23,9)
8"	25,7 (59,6)	90,1 (100,7)
8" Z	21,7 (36,5)	55,3 (61,8)

For models with suffix "Z" the longest paddle must be used to obtain the values indicated on the table.  
Pressure drop at the maximum flow (Qmax): 0,08 bar

③

**FLOW RATE WITH „T“ PIPE FITTING**  
NSF-3E / -4E / -6E

NSF-	Pipe connector with „T“ pipe fitting Ø	Min. adjustment m <sup>3</sup> /h cut-off (cut-in)	Max. adjustment m <sup>3</sup> /h cut-off (cut-in)
3E	1/2"	0,174 (0,48)	0,846 (0,948)
4E	3/4"	0,138 (0,408)	0,768 (0,858)
6E	1"	0,2 (0,6)	1,0 (1,1)

The "T" connectors have cylindrical GAS thread.

Paddles (models without "T" pipe fitting)

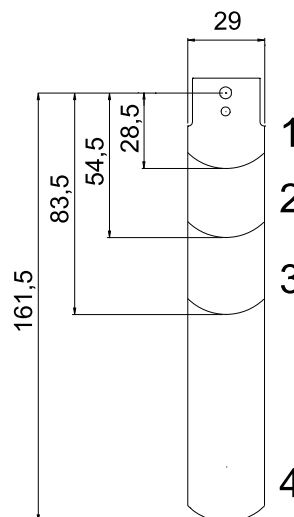

PIPE	PADDLES
1"	1
1 1/4"	1
1 1/2"	1
2"	1,2
2 1/2"	1,2
3"	1,2,3
4"	1,2,3
4" Z	1,2,3,4
5"	1,2,3
5" Z	1,2,3,4
6"	1,2,3
6" Z	1,2,3,4
8"	1,2,3
8" Z	1,2,3,4

## ELECTRICAL WIRING

Diagram during flow presence.

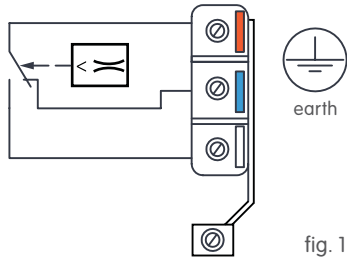

fig. 1

Adjustment screw for flowrate

Connect the red and the white contacts of the microswitch (fig. 1). The contact red-white opens when the flow drops below the set level.

When the flow is missing the contact red-blue closes and can be used as a signal or alarm contact.

## INSTALLATION

The flowswitch can be installed in every position far from elbows or throttlings, with arrow on flow direction. If pipe is vertical, recalibrate range to balance paddle weight. If the device is downwards mounted take care to slugs, and apply it in a straight pipe far from filters, valves, etc with length at least 5 times the diameter of pipe upstream and downstream the unit.

## NOTE

The flowswitch is factory calibrated at its min. sensitivity. To increase the set value turn clockwise the adjustment screw. The cut-out value must be >- the minimum flow necessary to guarantee the protection of the plant. The units without "T" fittings are supplied with 4 paddles, which must be cut off according to the pipe. All devices can be supplied with "T" connection on request as schedule indications.

## ATTENTION

If flowswitch is used as a minimum flow controller, it is necessary to add another device downstream for alarm condition activation.

## DIMENSIONS (mm)

### NSF

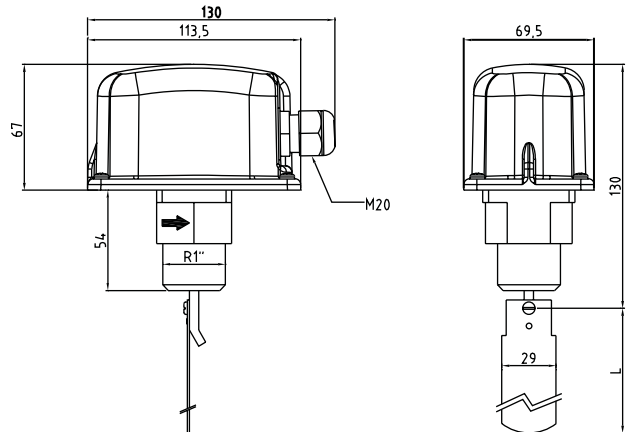

### NSF/PL

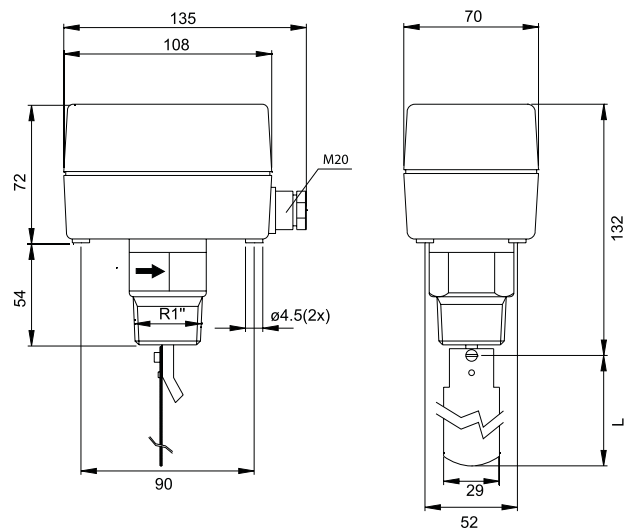

L changeable length (see the drawing of the paddles)

## MOUNTING INSTRUCTIONS

